

**PRODUCTS FOR PLATERS**

**STERLING  
SYSTEMS**

## The Sterling Barrel... The Plater's Choice

Developed by platers for platers. Sterling's original mesh barrel\* provided the first practical method for plating a wide range of thin or miniature parts. When Sterling developed the square hole cylinder, the combination of maximum solution transfer and current flow in a tough, durable unit became practical for all your barrel plating needs.

Of equal importance is the straightforward overall design that recognizes the plater's need for equipment which operates day after day, year after year, without constant attention. If required, Sterling's exclusive motor cartridge can be changed in seconds...or the cylinder quickly replaced - to keep your system going.

Backing up this performance and common sense design is Sterling's reputation for quick response to unusual requirements plus an unmatched stock of complete barrels, components and accessories for off-the-shelf-delivery.

Add up the advantages. Sterling... the best system to solve your plating problems.

\*U.S. Patent Nos. 3472753, 3498902  
Other domestic and global patents also apply.



*FACT: Sterling's mesh cylinder drains faster than any other*



Certain Sterling cylinders feature this unique end panel mesh construction. This additional mesh provides even greater solution and current transfer resulting in faster, more uniform plating with reduced dragout. Another design improvement from the long-time leader in portable plating barrels...Sterling. For complete ordering information, please contact our factory or consult your Sterling representative.

# Standard Components For Better Performance



CYLINDER PANELS

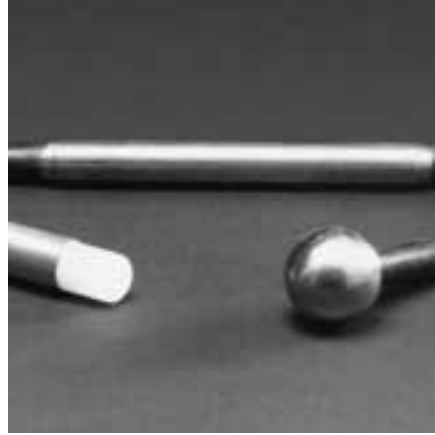

DANGLERS



MOTOR CARTRIDGE

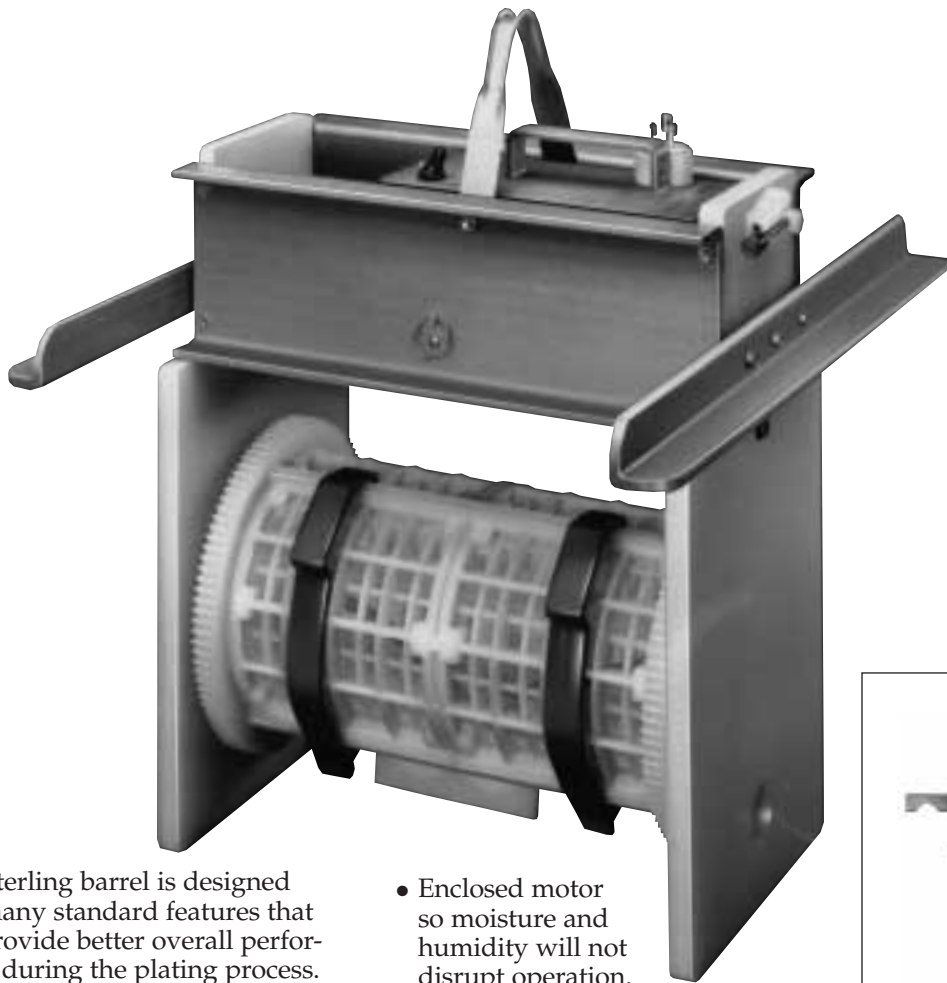

Each Sterling barrel is designed with many standard features that help provide better overall performance during the plating process.

- Cylinder panels to enhance solution transfer (parts will not stick to mesh sides).
- Quick – acting clutch for proper positioning of cylinder when loading and unloading.
- Interchangeability of mesh or square hole cylinders allows you freedom for full utilization of your equipment.

- Enclosed motor so moisture and humidity will not disrupt operation.
- Lift tab for easy door opening.
- Our rugged construction – designed for long service – helps to eliminate rejects caused by part-catching joints.

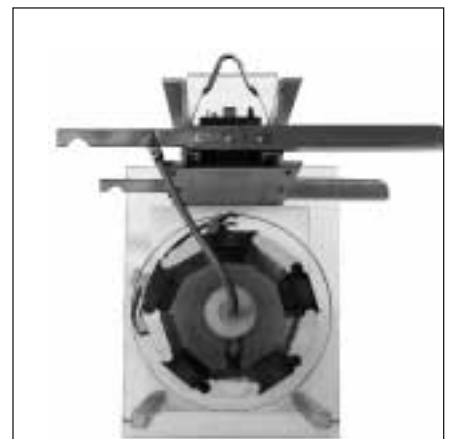

TONGUE AND GROOVE

*Our rugged construction – designed for long service – helps to eliminate rejects caused by part-catching joints.*

## Button Contact Barrels

Sterling's Button Contact and Rotating Center Bar Barrels feature our exclusive – rotating DC contact for maximum current supply and easy maintenance. Sterling has designed many button contact barrels to handle a wide range of load sizes. Barrels are made for plating everything from delicate wire leads to nuts and bolts.

All models feature our exclusive interchangeable motor cartridge. Our convenient clutch allows rapid positioning of the cylinder when loading or removing your parts. Barrels come equipped with stainless hardware below solution level for most applications with titanium hardware available for strong acid baths. Mesh types B, C, C-1, or square hole cylinders are available.

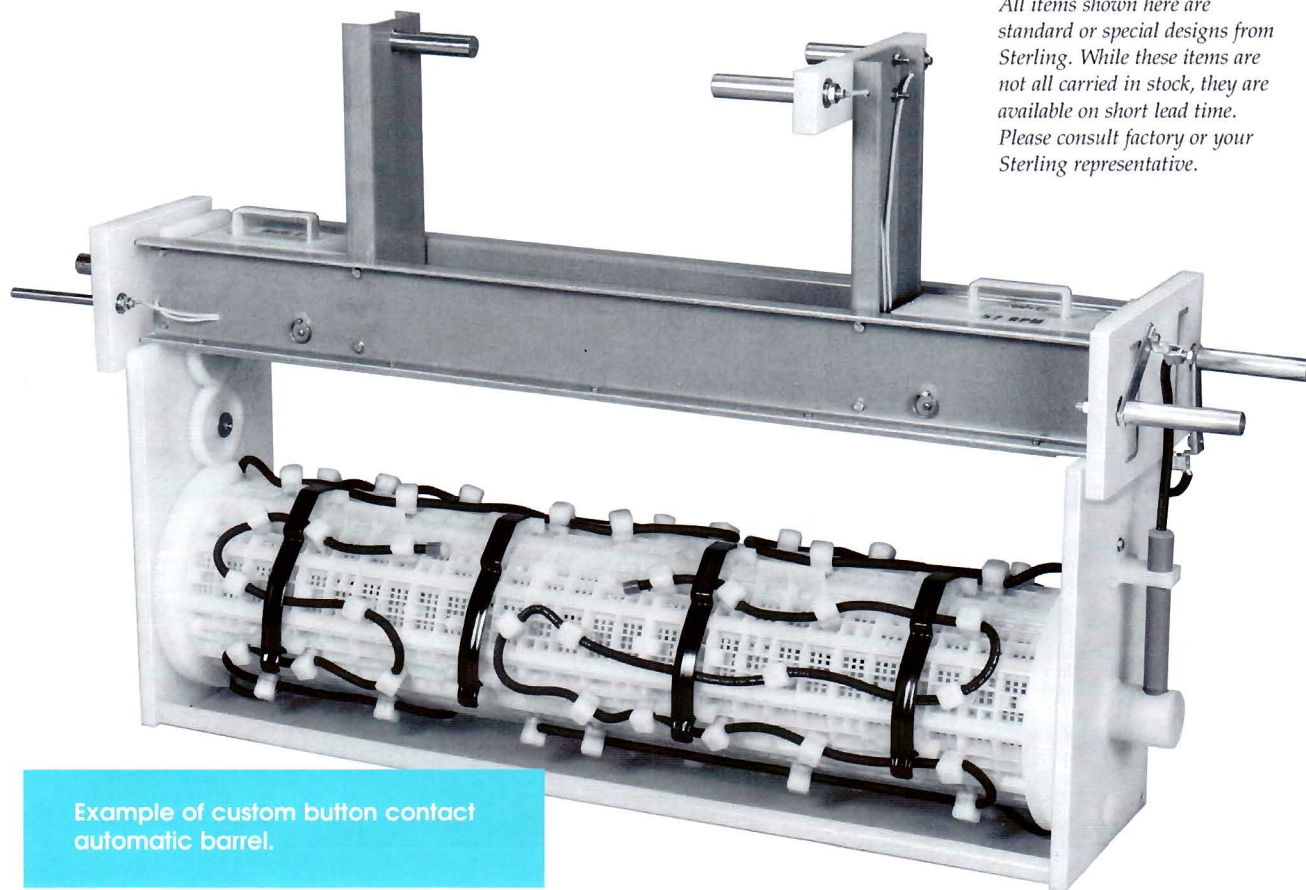
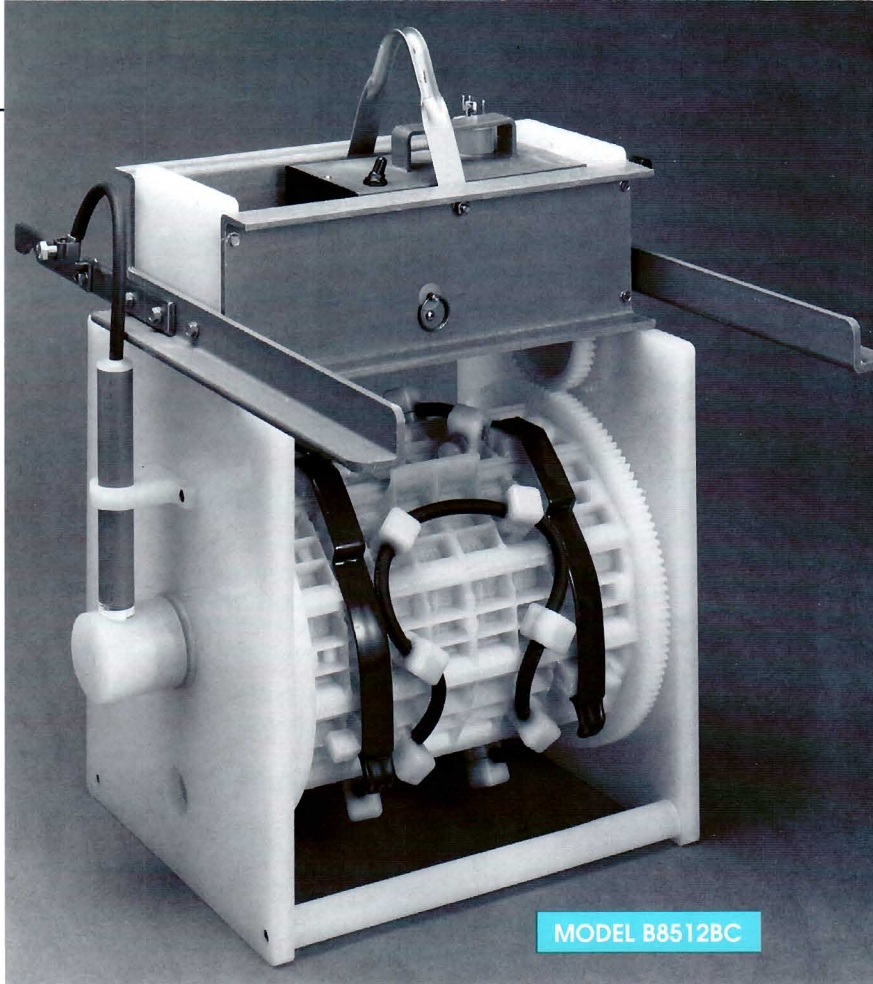

*All items shown here are standard or special designs from Sterling. While these items are not all carried in stock, they are available on short lead time. Please consult factory or your Sterling representative.*

# Custom Automatic Barrels

Whatever your barrel needs, Sterling has a system that will work for you. Engineering firms frequently look to us for optimum barrel utilization in their plating barrels designs.

Sterling builds original replacement equipment for all types of automatic barrel or rack lines. The most exotic transfer mechanisms or contact assemblies are no problem at Sterling – our only limitation is your imagination.

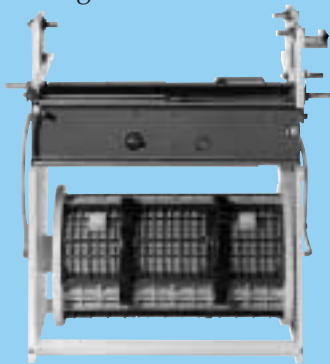

## MODEL 918 CUSTOM

A perfect example of how Sterling can meet your plating needs. This model is built to fit an automatic plating line. This configuration is equipped with horn contacts for plating current and drive power and electrified top contacts for cylinder rotation between stations. A variable speed cylinder motor operates on low voltage AC. All Sterling barrels can be adapted to your present or proposed transfer mechanisms.

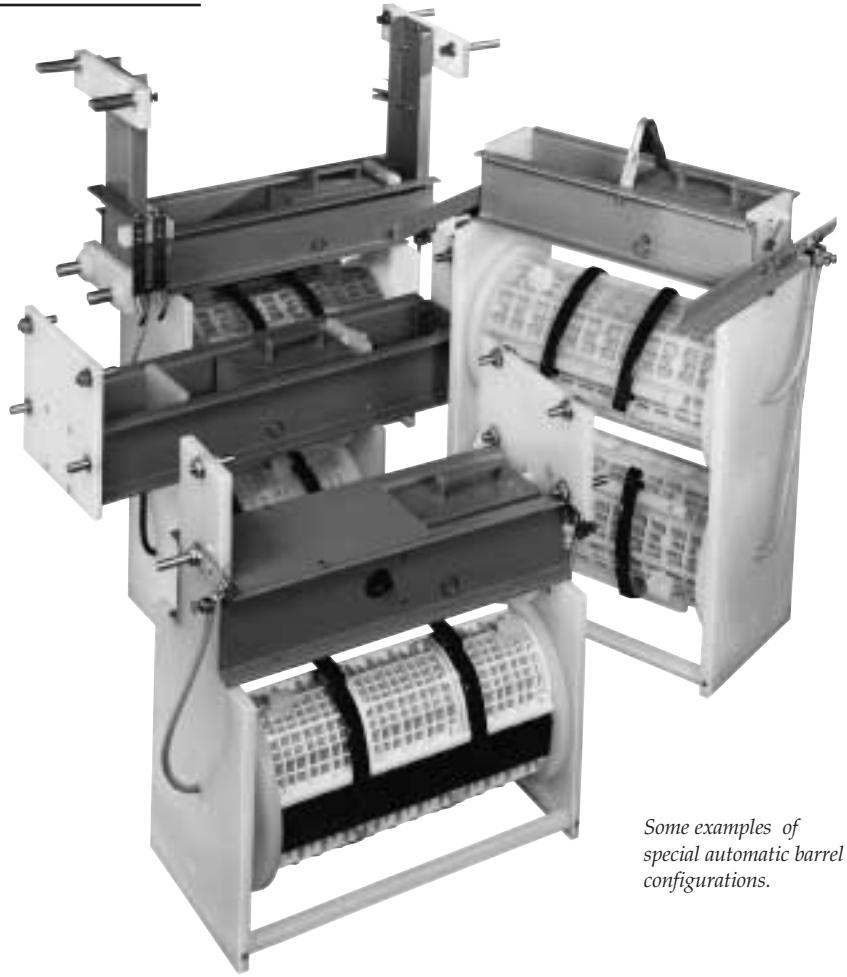

*Some examples of special automatic barrel configurations.*

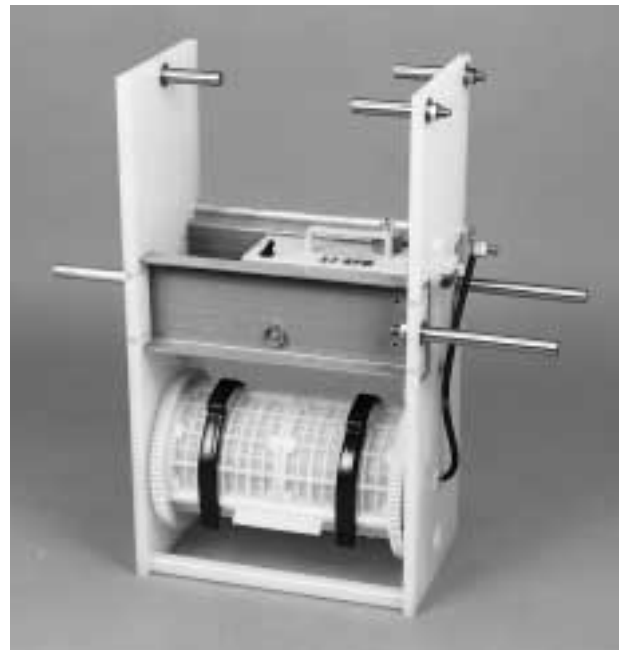

*When ordering, specify: Model number, motor RPM, cylinder style, dangler type, and hardware below solution level. Sterling custom builds cylinders for use with most standard plating barrels.*

# Miniature Barrels

## MODEL 44, 46, AND 56

Our miniature barrels feature all molded construction and also include our all-around mesh design. They have their own motors, danglers, and replaceable cylinders. Available in C, C-1 or B mesh.

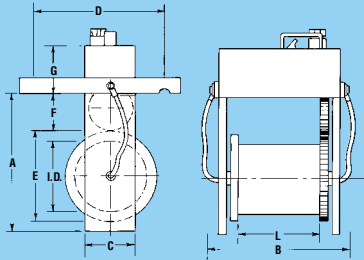

\*Specify "EXTENDED" after model number for additional 3" depth on side panels.

## MODEL HD24-SUPER

This is the complete horizontal mini-plating barrel for your operation, featuring our unique 2½" x 4" basket, which is available in single, double and triple configurations. This series is great for miniature production runs. Designed with mesh ends and constructed to provide uniform coverage, good mixing action and positive part retention. No door or section joints are present to trap tiny parts. Rugged construction is ideal for small lot production runs. Miniature barrels are designed with stainless hardware below solution level for most applications with Titanium hardware available for strong acid baths. Models available with choice of B, C, and C-1 mesh.

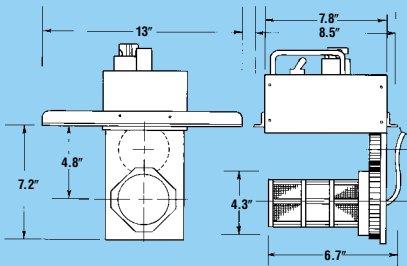

Dimensions in inches. Load at 1/3 full 6 cu. in.  
\*Specify "EXTENDED" after model number for additional 3" depth on side panel

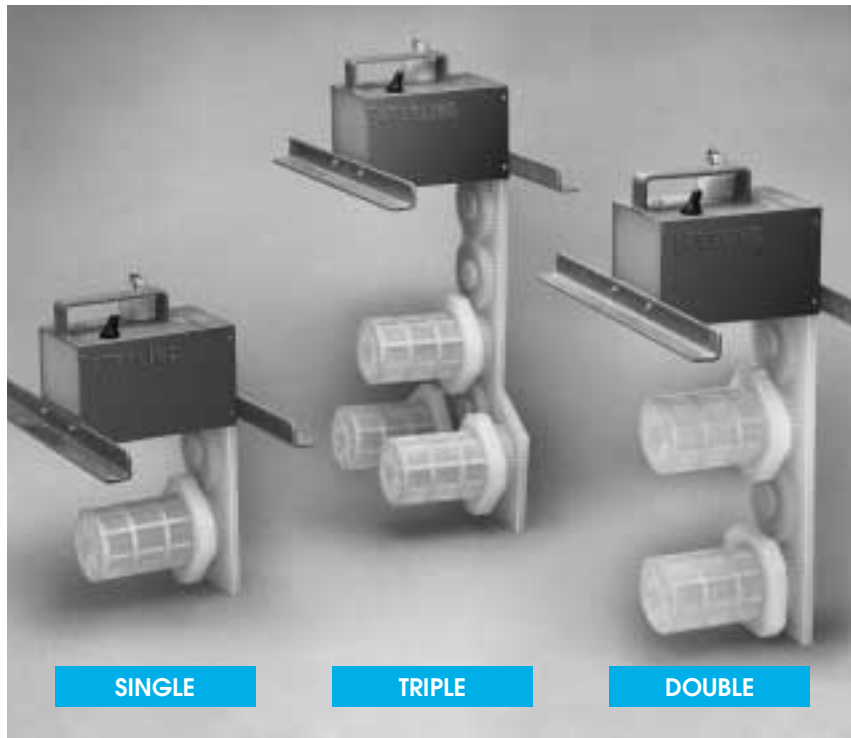

MODEL	CYLINDER SIZE I.D. X L (IN.)	APPROX. NO LOAD WEIGHT	A*	B	C	D MAX	E OVER CLAMPS	F* CATHODE ROD TO CYLINDER	G	MOTOR RPM 30/60	LOAD SIZE 1/3 FULL (CU. IN)
										CYLINDER SPEED	
44	4 x 4	7½	10⅞	6¼	3¾	12	6½	3¾	3½	10/20	17
46	4 x 6	8	10⅞	8¼	3¾	12	6½	3¾	3½	10/20	25
56	5 x 6	8½	10⅞	8¼	3¾	12	6½	3¾	3½	10/20	47

All dimensions in inches.

Other speeds and DC available.

## Medium Barrels

Medium barrels are designed to handle a wide range of load sizes and feature our exclusive interchangeable motor cartridge. These barrels also feature our convenient clutch which allows rapid positioning of the cylinder when loading or removing parts.

Medium barrels also come with stainless hardware below solution level for most applications or Titanium hardware for strong acid bath applications. Styles include B, C, C-1 or square hole cylinder.

When ordering please specify plastic tipped rod dangler, ball dangler, or floating rod dangler types, motor RPM and mesh type required.

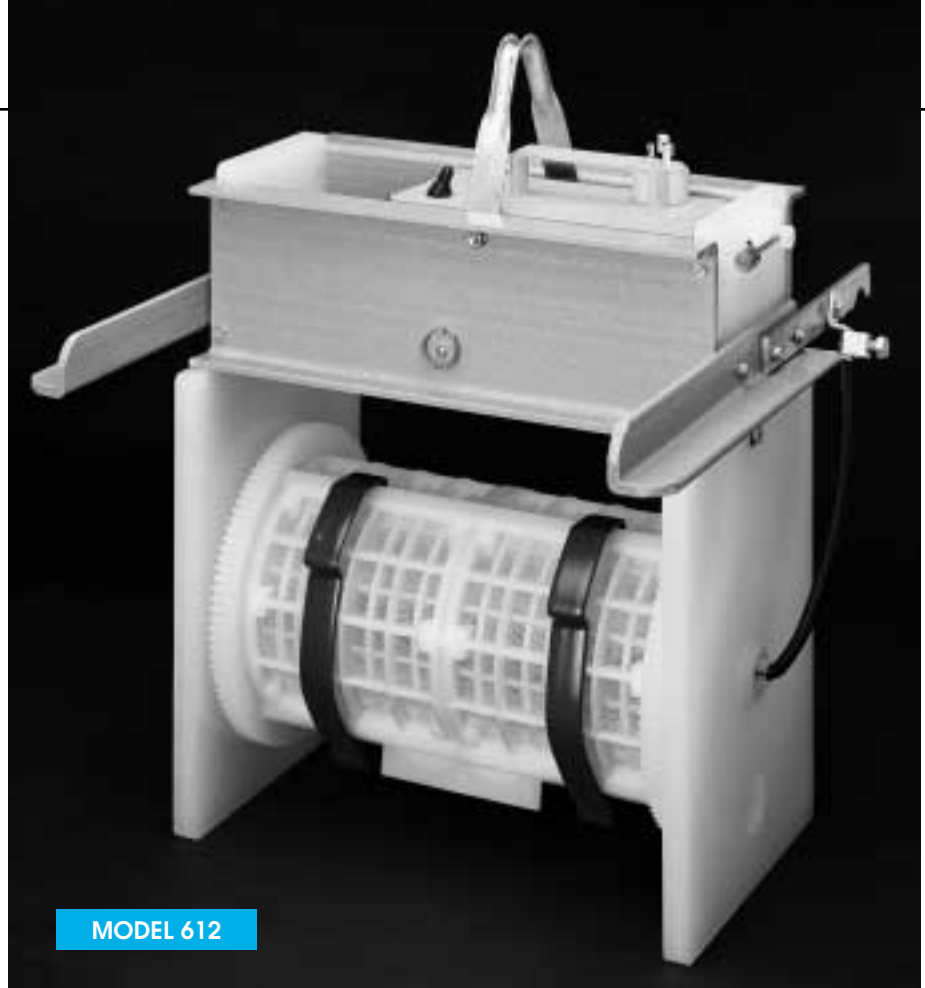

MODEL 612

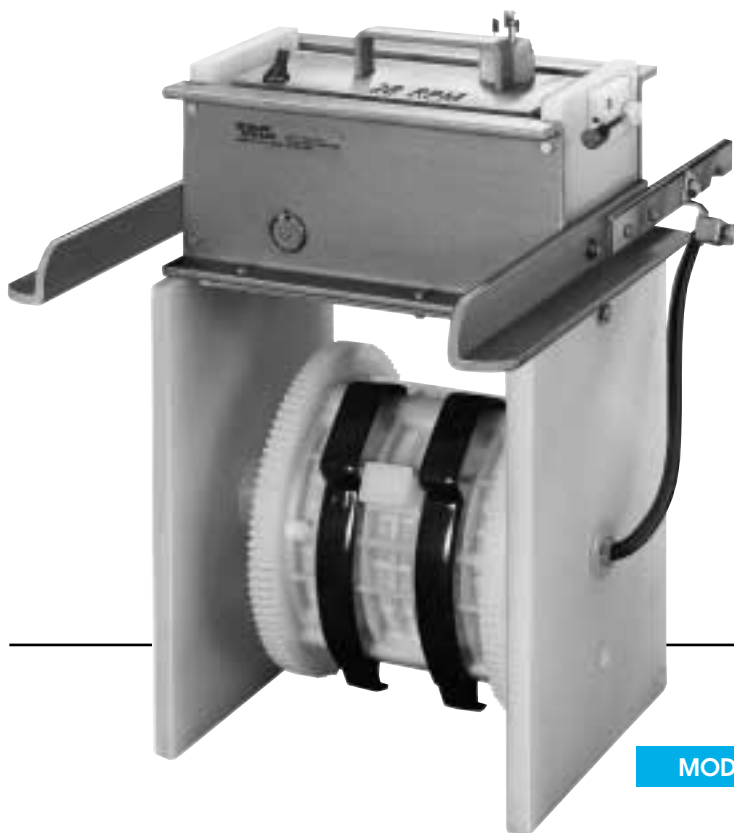

MODEL 66

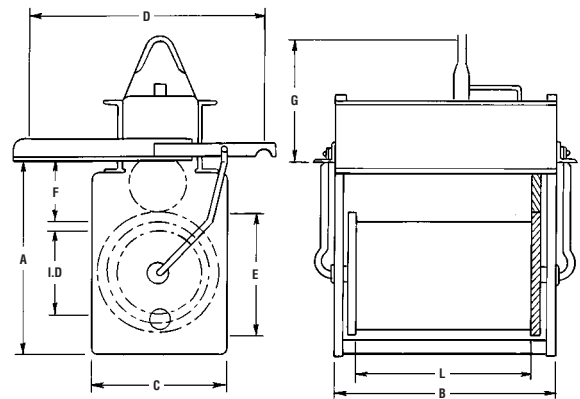

When ordering, specify: Model number, motor RPM, cylinder style, dangler type, and hardware below solution level. Sterling custom builds cylinders for use with most standard plating barrels.

# Medium Barrels With Delta Cylinders

Model 8512 shown here with a delta cylinder (also shown below) is excellent for part mixing action and solution transfer. This design improves the distribution of plated metals. The delta cylinder can be ordered on models 8512 and 918 – both models come standard with flat panel cylinders.

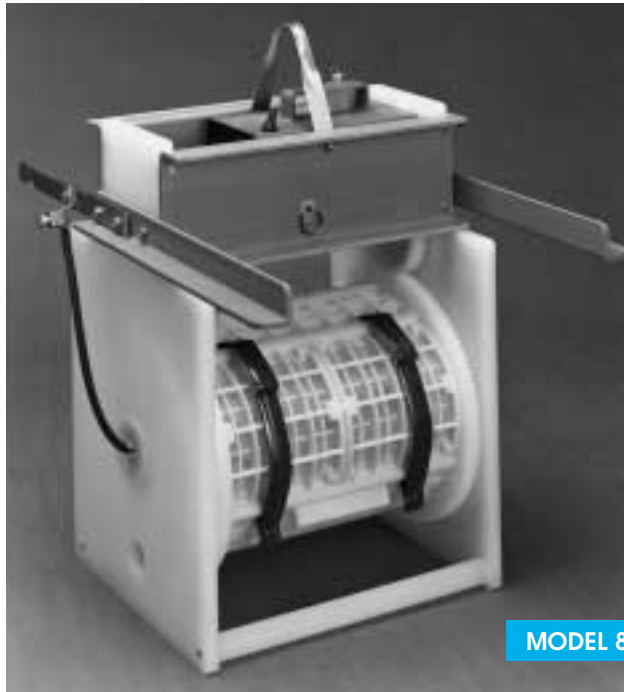
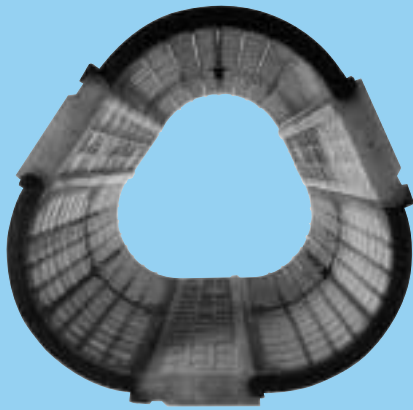

**MODEL 8512 DELTA**

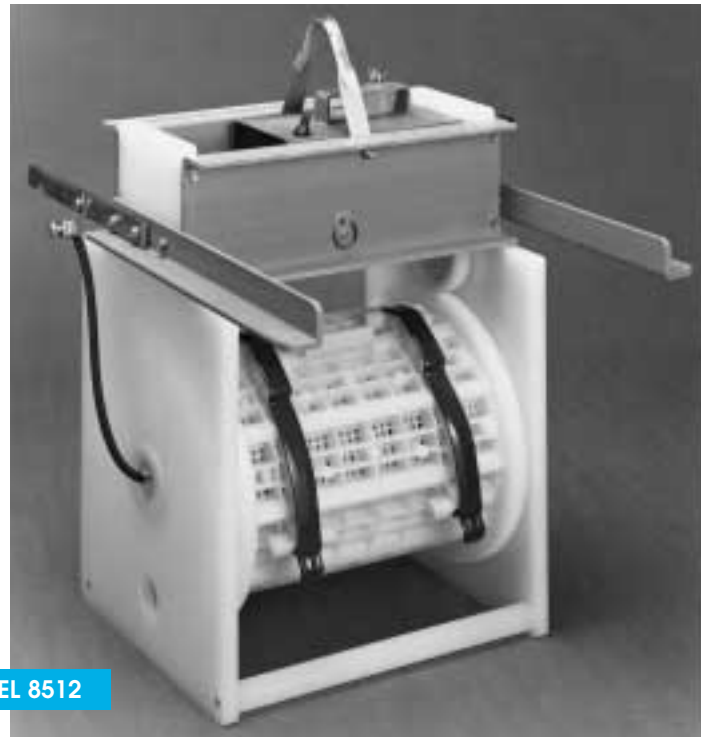

**MODEL 8512**

MODEL	CYLINDER SIZE I.D. X L (IN.)	APPROX. NO LOAD WEIGHT	A*	B	C	D MAX	E OVER CLAMPS	F* CATHODE ROD TO CYLINDER	G	SPEED (RPM) **MOTOR RPM			LOAD SIZE 1/3 FULL (CU. IN)
										28	57	94	
66	6 x 6	23	13%	11	9	15%	9 1/4	4 1/2	8 1/4	6.0	12.5	18.0	56
612	6 x 12	25	13%	15	9	15%	9 1/4	4 1/2	8 1/4	6.0	12.5	18.0	112
8512	9 x 12	33	15%	15	11 1/2	19%	12 1/4	4 1/2	8 1/4	4.6	9.5	13.7	190
918	9 x 18	38	15%	21	11 1/2	19%	12 1/4	4 1/2	8 1/4	4.6	9.5	13.7	285
1018	10 x 18	45	19%	21	11 1/2	19%	14 3/4	4 1/2	8 1/4	3.6	7.5	10.8	426
1024	10 x 24	57	19%	27	11 1/2	19%	14 3/4	4 1/2	8 1/4	3.6	7.5	10.8	570

*All dimensions in inches.*



## Larger Capacity Barrels

Our largest capacity barrels are designed for volume production runs or where more area or volume is needed. Rugged flat panel cylinders are available in all mesh styles or square hole design. The larger capacity barrels feature stainless hardware below solution level for most applications and can also be constructed with titanium hardware for strong acid bath applications.



MODEL 918

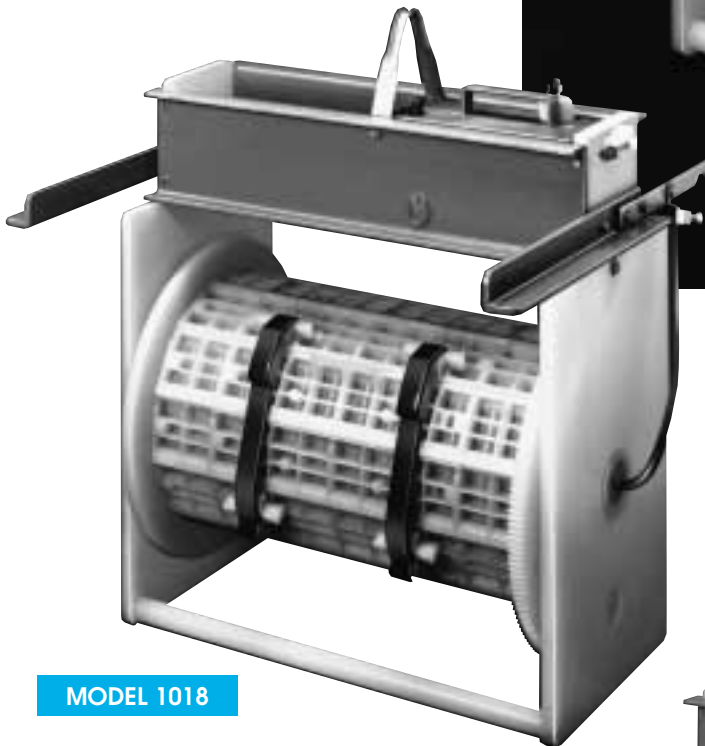

MODEL 1018

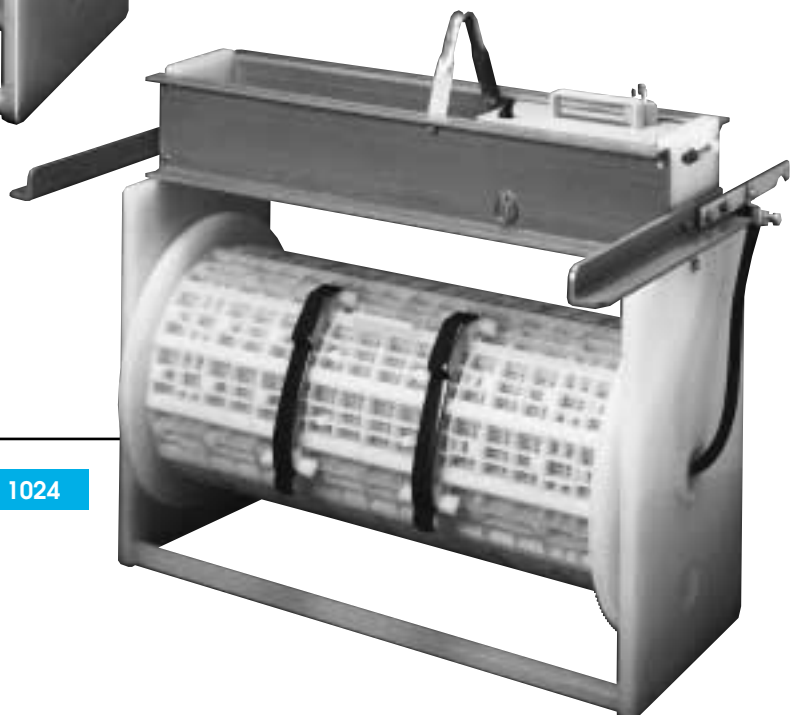

MODEL 1024

# Sterling Designs Quality Components In...



## MOTOR CARTRIDGE

Interchangeable for models 66 thru 1024. This unit is self-contained with all electrical components encased in tough polypropylene housing. The inlet is 3-wire grounded and the toggle switch is protected by a rubber boot. The stainless steel retainer pin easily removed for changing cartridge.

- 28 and 57 RPM standard. Optional: 10, 100, 140 RPM, variable speed, 12 and 24 volt DC, 36 volt AC..
- Models 46 and 56, same as above, except 30 and 60 RPM standard.
- Models 24 and 44, same as above, except 30 and 60 RPM standard, in special compact design. Specify "JR" motor when ordering.

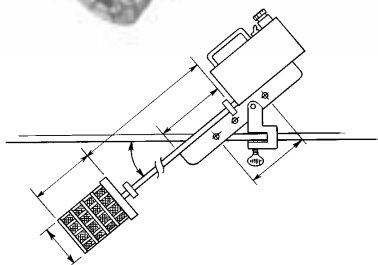

## CYLINDER PANELS

Sterling mesh panels achieve maximum open area for better current flow and solution transfer. They contain and efficiently process extremely small, thin or delicate parts. Sterling's square hole design is made for large parts or heavier loads.

Panel Construction	Opening Size (in.)	Features
B Mesh	.030 Nom.	Maximum open area best drainage of mesh types.
C Mesh	.020 Nom.	Best general mesh Supplied as standard equipment.
C-1 Mesh	.010Nom.	When parts would pierce C Mesh. Slower Drainage.
Square Hole	.095 Nom.	For heavier loads, larger parts. Molded holes for strength.
Square Hole	.220 Nom.	Same as .095

## OBLIQUE SERIES

Small lots plate easily in 2-1/2" x 4" basket. With 6" x 6" or 6" x 11" baskets, these models can plate larger amounts. The same motor unit, with a universal tank rim clamp, drives all basket, shaft and dangler assemblies. Also this series is convenient for flash plating by hand and is an ideal alternative to horizontal barrels where space is limited. Comes complete with mesh baskets and dangler.



## DANGLERS

Flexible, high capacity, leakproof. Plastic tipped rod type is recommended for all mesh cylinders. Stainless steel, copper or brass available. Sterling will also include special fixtures such as interrupter bars inside any cylinder. Please specify as needed.



## RETROFIT SERVICE

Sterling will retrofit any existing barrel with one of our unique mesh cylinders...at no additional cost. Contact Sterling for details.

Basket size	A	B	C	D	Motor RPM
2½ x 4	19½	4	2½	0°-60°	10
6 x 6	24¾	6	6	0°-60°	10
6 x 11	24¾	11	6	0°-60°	10

# Aqueous Cleaning

Be CFC - free with a Sterling parts cleaning system

Replace solvent degreasing systems with a complete line of aqueous cleaning systems featuring the Sterling barrel. Standard System features a choice of cleaning barrels in available off-the-shelf configurations. Rinsing is accomplished in a combination of unloading and rinsing station designed for ease of parts handling. A complete system features degreasing, rinsing and drying operations with ease of handling. Degreasing tank features in-tank filtration, oil separation, temperature control and both solution and parts agitation.



Sterling Bulk Parts cleaning system is versatile, low cost, and compact. Call our 1-800 number for prices on a complete system.



Sterling Barrel features heavy duty polypropylene square hole construction for heavy parts or mesh construction for smaller parts.



Centrifugal Dryer offers efficient hot air drying of small parts. Spins the basket of parts while hot air evaporates the final traces of moisture.

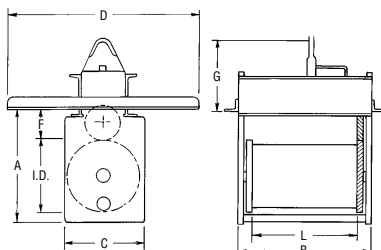

When ordering, Specify: Model number, motor RPM, cylinder style. Rugged flat panel square construction is recommended. Available in .093 or .220 opening standard.

MODEL	CYLINDER SIZE I.D. X L	APPROX. NO LOAD WEIGHT	A	B	C	D	E OVER CLAMPS	F SET DOWN TO CYLINDER	G	MOTOR SPEED RPM		LOAD SIZE 1/2 FULL
										30	60	
										CYLINDER RPM		
B612K	6 x 12	25 lbs.	13 <sup>5</sup> / <sub>16</sub>	15	9	22	9 <sup>1</sup> / <sub>4</sub>	4 <sup>1</sup> / <sub>8</sub>	8 <sup>11</sup> / <sub>16</sub>	6.0	12.5	112 cu. in.
B912K	9 x 12	35 lbs.	15 <sup>5</sup> / <sub>8</sub>	15	11 <sup>3</sup> / <sub>8</sub>	22	12 <sup>1</sup> / <sub>4</sub>	4 <sup>1</sup> / <sub>8</sub>	8 <sup>11</sup> / <sub>16</sub>	4.6	9.5	190 cu. in.

All dimensions in inches.

## Baskets For Cleaning Rinsing, Drying, Batch Processing, etc.

Sterling offers a variety of unique parts' baskets for many applications. Handling, processing and finishing operations often require lightweight, fast draining parts' baskets and, at Sterling, these are a specialty. From nuts and bolts to delicate micro-electronic components, Sterling makes a basket for your part loads.

In stock baskets are available in all sizes shown. Frames are molded from glass-filled polypropylene and superior quality mesh is offered in stainless steel or polypropylene materials.

SIZES	DESCRIPTION
2½ x 4	Polypropylene Mesh
6 x 6	Polypropylene Mesh
6 x 6	Stainless Mesh
12 x 12	Polypropylene Mesh
12 x 12	Stainless Mesh

*All dimensions in inches.*



## **STERLING SYSTEMS**

PRODUCTS FOR PLATERS

3745 Stern Avenue  
St. Charles, IL 60174  
Telephone: (630) 584-3580  
Fax: (630) 584-4016

Specifications subject to change.  
Contact Sterling for details.

Distributed By:



# **LUSTER-ON**

1-800-888-2541  
54 Walham Avenue  
Springfield, Massachusetts 01109